

Fire Brigade Interface

FWI2-1/FWZ2-1

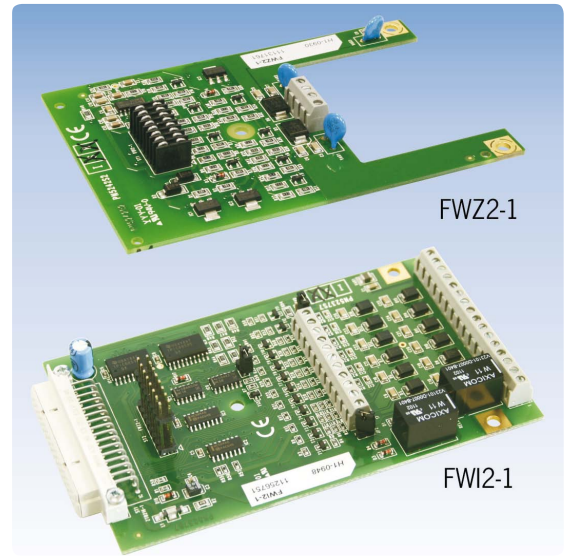

- **2 independent relay outputs**
- **9 inputs and 8 outputs for control tasks**
- **Connection of country-specific fire brigade control units**
- **Line-monitoring by means of auxiliary module**



Description

The Fire Brigade Interface FWI2-1 by means of dry contacts allows for the connection of two independent transmitting devices for the direct interconnection with a designated alarm respondent (e.g., the fire brigade) as well as the connection of a country-specific fire brigade control unit to Fire Detection Control Panels Series BC216.

The parameters of the nine inputs and eight outputs can also be freely set and thus are available for general control tasks. Optionally, the Fire Brigade Interface Additional Board (FWZ2-1) can be attached to the Fire Brigade Interface. This unit allows for the connection of two independent, line-monitored transmitting devices. The monitoring current can be adjusted in three levels.

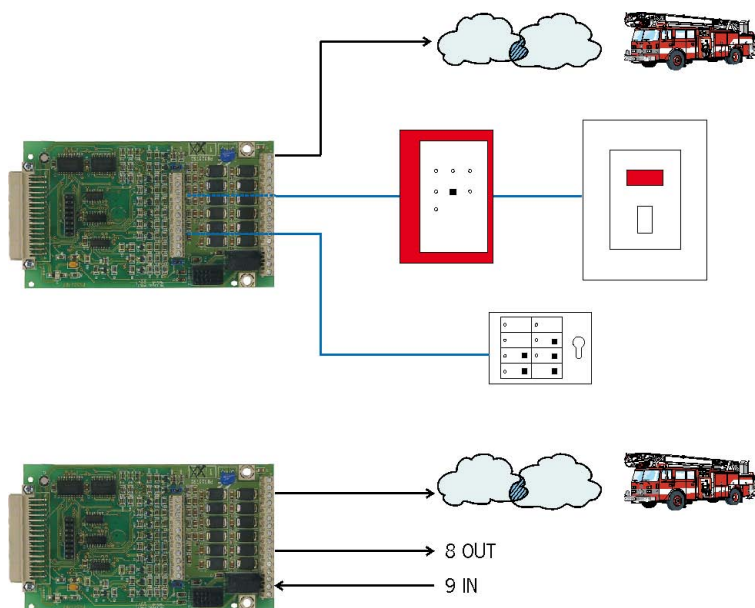

Building Safety. Building Security.

Specifications

FWI2-1

Current consumption at 24V	typ. 4mA
Switching power per contact	60V/1A/30W
Contact life	3 × 10 ⁵
Ambient temperature	-5°C to +50°C
Dimensions L × W × H	132 × 74 × 23 (mm)
Weight	70g
Order number	214022
Order name	Fire Brigade Interface FWI2-1

FWZ2-1

Current consumption at 24V	typ. 4mA (both outputs not connected) max. 28mA (both outputs connected)
Ambient temperature	-5°C to +50°C
Dimensions L × W × H	117 × 74 × 13 (mm)
Weight	70g
Order number	214023
Order name	Fire Brigade I/F Additional Board FWZ2-1

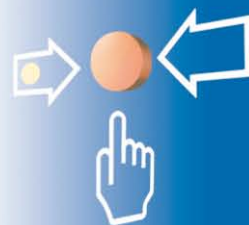

Building Safety. Building Security.

LST